

# Mounting Sleeve WF-MS



**For WOODFORD Wall Faucets - Models 14, 16, 17 & 19 ONLY**

*Patent Pending*

The Woodford Wall Faucet Mounting Sleeve (WF-MS) takes the guesswork out of how far to stub-out Woodford freezeless faucets through brick, stone or stucco veneers. It also provides a secure anchor for the faucet.

The Mounting Sleeve allows the plumber to determine a stub-in location and set an adjustable finish depth required by the brick or stone mason. A numbered scale is built into the top of the Mounting Sleeve.

The faucet installation is completed by mating the faucet wall flange to the front of the Mounting Sleeve and securing with two, furnished flange screws. The proper drain angle is automatically set by the rear Tube Rest.



**Finished brick and mortar with faucet attached to Mounting Sleeve**



**Mounting Sleeve Parts**



**Mounting Sleeve adjusted for depth and attached to wall**

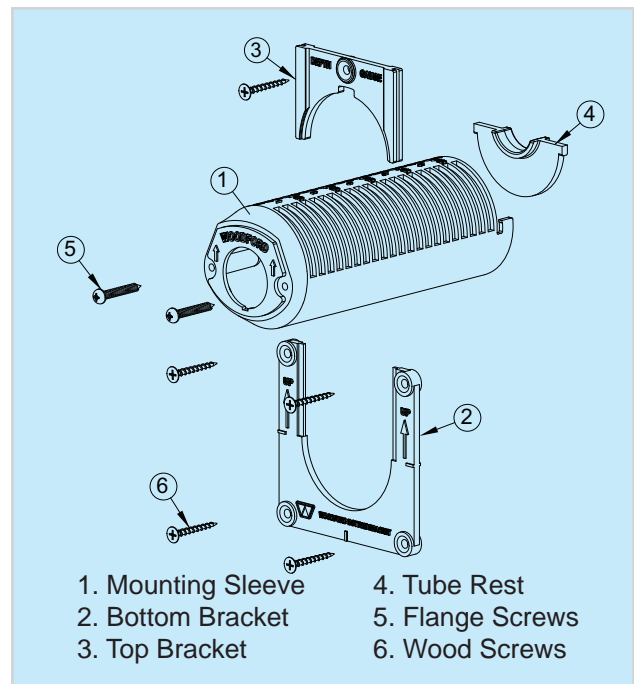

**\$10.50 List Price Each  
- Sold 10 to a carton -**

*See reverse side for installation instructions.*

## WF-MS

### Wall Faucet Mounting Sleeve Installation Instructions

For Woodford Models 14, 16, 17, 19 ONLY

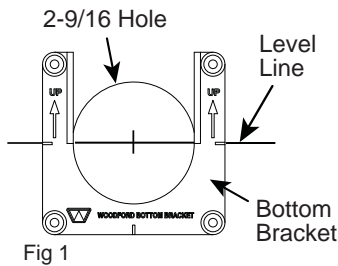
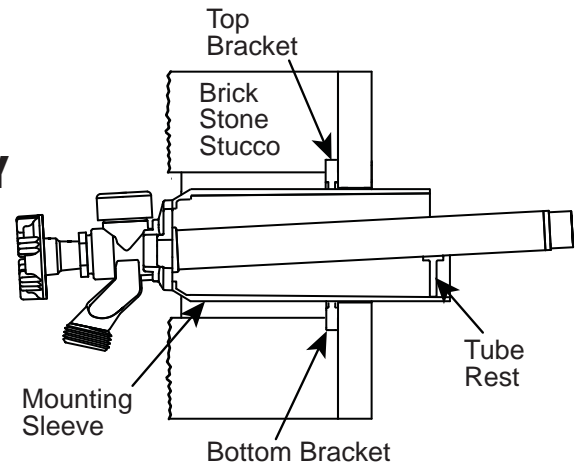

Fig 1

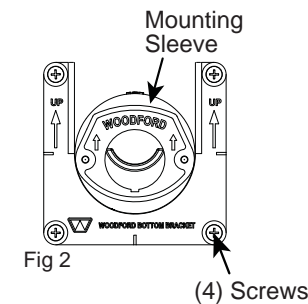

Fig 2

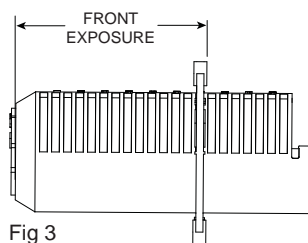

Fig 3

1. Determine the wall surface where the Mounting Sleeve will be located. Fig 1
2. Draw a level line, center and drill a 2-9/16" hole. Fig 1
3. Align the Bottom Bracket, arrows pointing up, with the hole and level line. (The Mounting Brackets can be installed on the inside wall or the outside of the wall) Fig 1
4. Use (4) of the furnished wood screws to secure the Bottom Bracket. Fig 2
5. Slide Mounting Sleeve through the hole. Use the number scale on top of the Mounting Sleeve to determine exposure distance. Fig 3
6. Slide the Top Bracket over the Mounting Sleeve and into the Bottom Bracket. Fig 4
7. Lock the Top Bracket into one of the Mounting Sleeve slots. Use the remaining wood screw to secure the Top Bracket. Fig 5
8. Be sure the Tube Rest is seated in the slots on the back end of the Mounting Sleeve. The Tube Rest provides the proper faucet drain angle position. Fig 6

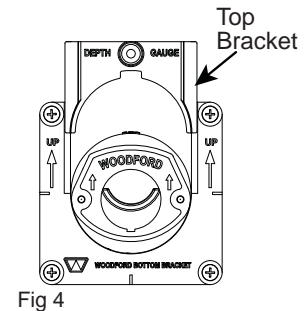

Fig 4

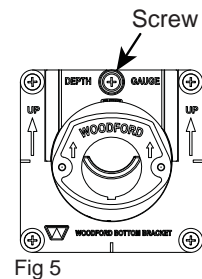

Fig 5

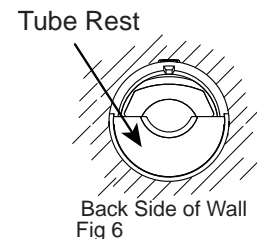

Fig 6

**Note: If soldering to an inlet make sure heat is far enough away from the Mounting Sleeve or Tube Rest to prevent damage.**

For more information contact...

**WOODFORD MANUFACTURING COMPANY**

2121 Waynoka Road, Colorado Springs, Colorado 80915 • Phone: (800) 621-6032 • Fax: (800) 765-4115

To view our complete product line visit: [www.woodfordmfg.com](http://www.woodfordmfg.com) or email: [sales@woodfordmfg.com](mailto:sales@woodfordmfg.com)

A Division Of WCM Industries, Inc.